

## 3107G Air Die Grinder Exploded Diagram

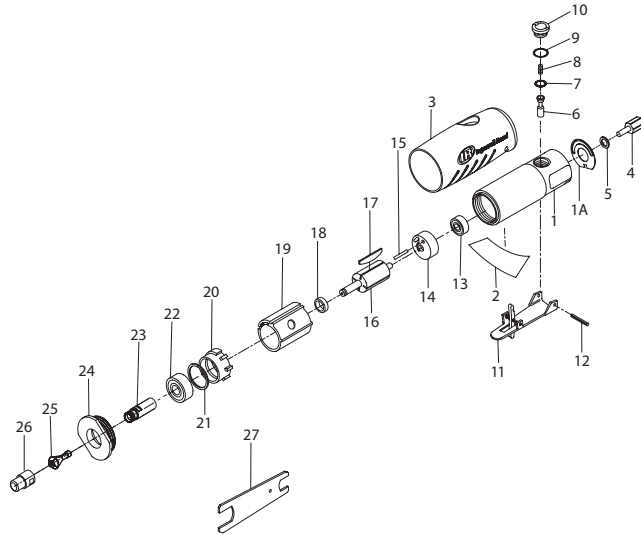

(Dwg. 16586042)

### 3107G Air Die Grinder Parts List

Item	Part Description	Part Number	Item	Part Description	Part Number
1	Housing Assembly	3101-A40	14	Rear End Plate	3101-12
1A	Gasket	3101G-283	15	Spring Pin	3101-504
2	Label	3107G-301A	16	Rotor	301-53
3	Sleeve	3101G-747	17	Vane Set	301-42-4
4	Inlet Bushing Assembly	3102-565	18	Spacer	301-448
5	Inlet O-Ring	3102-158	19	Cylinder	3101-3
6	Throttle Valve	3102-302	20	Front End Plate Assembly	307A-A11
7	Valve O-Ring	301-159	21	Gasket	3101G-36
8	Valve Spring	3102-51	22	Ball Bearing	301-24
9	Valve Cap O-Ring	301-206	23	Collet Body	307A-214
10	Valve Cap	3102-266	24	Clamp Nut	3107-27
11	Lever Assembly	3101-A400	25	Collet	301-700
12	Spring Pin	3101-504A	26	Collet Nut	301-699
13	Ball Bearing	301-22	27	Wrench	301-69

### Parts and Maintenance

When the life of the tool has expired, it is recommended that the tool be disassembled, degreased and parts be separated by material so that they can be recycled.

Tool repair and maintenance should only be carried out by an authorized Service Center.

Refer all communications to the nearest **Ingersoll Rand** Office or Distributor.

### Related Documentation

For additional information refer to:

Air Die Grinder Product Safety Information Manual 04580288.

Air Die Grinder Product Information Manual 16573487.

Manuals can be downloaded from [www.ingersollrandproducts.com](http://www.ingersollrandproducts.com).

