



16573347
Edition 2
February 2014

Air Grinder

Series 88H

Maintenance Information



Save These Instructions

 **Ingersoll Rand**®

Product Safety Information

WARNING

- Failure to observe the following warnings, and to avoid these potentially hazardous situations, could result in death or serious injury.
- Read and understand this and all other supplied manuals before installing, operating, repairing, maintaining, changing accessories on, or working near this product.
- Always wear eye protection when operating or performing maintenance on this tool. The grade of protection required should be assessed for each use and may include impact-resistant glasses with side shields, goggles, or a full face shield over those glasses.
- Always turn off the air supply, bleed the air pressure and disconnect the air supply hose when not in use, before installing, removing or adjusting any accessory on this tool, or before performing any maintenance on this tool or any accessory.
- Do not use this tool if the actual free speed exceeds the rated rpm. Check the free speed of this tool before mounting any accessories, after all tool repairs, before each job and after every 8 hours of use. Check speed with a calibrated tachometer, without the abrasive product installed.

Note: When reading the instructions, refer to exploded diagrams in Parts Information Manuals when applicable (see under Related Documentation for form numbers).

Lubrication

Whenever a Series 88H Grinder is disassembled for overhaul or replacement of parts, lubricate as follows:

Inject about 1.5 cc of **Ingersoll Rand Pneu-Lube®** Medium Lubricant No. 50 into the Inlet Bushing (4) after assembly. Fill the oil chamber. After each eight hours of operation, replenish the oil supply.

The use of an air line lubricator is recommended with these Grinders. Where the lubricator cannot be permanently mounted, we recommend using **Ingersoll Rand** No. 8LUB12 Lubricator.

For permanent installations, we recommend using **Ingersoll Rand** No. C31-06-G00 Filter-Lubricator-Regulator Unit. These units have 3/4" pipe tap, 1/2 pt. (237 ml) capacity. Larger capacity units may be used, but do not use a unit having less than a 3/4" pipe tap inlet and outlet.

Oiler Adjustment

The built-in lubricator has been properly adjusted at the factory. A lack of oil indicates the Oiler needs filling or the Oiler Felts are clogged and must be replaced as follows:

For Grip Handle Models

1. Remove the Arbor Housing Screws (30), Lock Washers (31) and Arbor Housing Gasket (32).
2. Remove the Oil Chamber Plug (24) and pour the oil from the oil chamber.
3. Using snap ring pliers remove the Oiler Retainer (19).
4. Insert a 1/4 x 20 (M6 x 1.0) machine screw in the pilot hole of the Oiler Body Assembly (18). See Dwg. TPD638.

5. Grasping the screw head with pliers, pull out the Oiler Body Assembly (18).
6. With a thin-blade screwdriver, unscrew the Oiler Adjusting Screw (20).
7. Using tweezers or a piece of bent wire, remove the Oiler Felts (21) and install a new set.
8. Replace the Oiler Adjusting Screw, installing it slightly below flush.
9. Replenish the oil supply.

For Lever Handle Models

1. Remove the Arbor Housing Screws (30), Lock Washers (31) and Arbor Housing Gasket (32).
2. Remove the Oil Chamber Plug (24) and pour the oil from the oil chamber.
3. Using snap ring pliers, remove the Oiler Retainer (19).
4. Insert lock ring pliers in the hole of the Oiler Body Assembly (18) and pull out the Oiler Body Assembly.
5. With a thin-blade screwdriver, unscrew the Oiler Adjusting Screw (20).
6. Using tweezers or a piece of bent wire, remove the Oiler Felts and install a new set.
7. Replace the Oiler Adjusting Screw, installing it slightly below flush.
8. Replenish the oil supply.

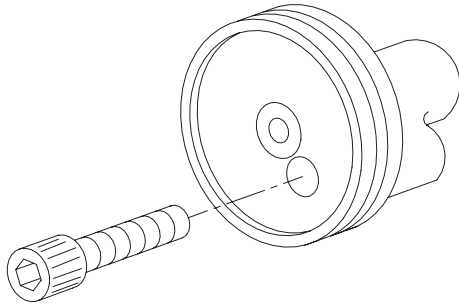

(Dwg. TPD638)

Disassembly

General Instructions

1. Do not disassemble the tool any further than necessary to replace or repair damaged parts.
2. Whenever grasping a tool or part in a vise, always use leather-covered or copper-covered vise jaws to protect the surface of the part and help prevent distortion. This is particularly true of threaded members and housings.

3. Do not remove any part which is a press fit in or on a subassembly unless the removal of that part is necessary for repairs or replacement.
4. Do not disassemble the tool unless you have a complete set of new gaskets and O-rings for replacements.

Disassembly of the Arbor

1. Grasp the Arbor Housing (29) in a vise, guard upward.
2. **For Type 1 Wheels (Models 88HG60H106 and 88HL60H106)**, use an appropriate spanner wrench inserted into the pinhole of the flange to hold the Arbor. Unscrew the Wheel Nut (50) with an open-end wrench. Remove the Wheel Flanges (51).
3. Unscrew the Guard Screws (52). Remove the Guard Screw Lock Washers (53) and the Wheel Guard (54).
4. **For Cone Wheel (Model 88HL90L10)**, using an R3F-340 Cone Wheel Arbor Wrench to hold the Arbor, unscrew the cone wheel counterclockwise. Loosen and unscrew the Bearing Cap (56) from the Arbor Housing.
5. Unscrew the Bearing Cap from the Arbor Housing.
6. Lift the Arbor (58) or (59) and the Arbor Coupling (49) from the Arbor Housing. Pull the Arbor Coupling off the Arbor.
7. Grasp the Arbor in a vise, spline end up.
8. With pliers, straighten the tangs of the Bearing Lock Washer (61). Unscrew the Bearing Locknut (60) and remove the Bearing Lock Washer.
9. If the Arbor Bearing (62) is to be replaced, press it from the arbor shaft.

Disassembly of the Motor and Throttle

1. Using the No. R2J-562 Deflector Screw Wrench, remove the Exhaust Deflector Screws (28) and lift off the Exhaust Deflector (25), Exhaust Deflector Gasket (26A), Exhaust Diffuser (27) in models where used and Exhaust Baffle (26).
2. Grasp the Arbor Housing (29) in a vise.
3. Unscrew the Arbor Housing Screws (30) and remove the Lock Washers (31).
4. Lift off the Throttle Handle Assembly (1) to expose the motor.
5. Remove the Arbor Housing Gasket (32).
6. Grasp the Controller Assembly (35) by hand and pull the motor unit out of the Arbor Housing (29).
7. Remove the Arbor Housing (29) from the vise. Turn over the Arbor Housing and the two Motor Clamp Washers (48) will drop out.
8. Grasp the Rotor Shaft (47) in the vise.
9. Remove the Controller Retaining Ring (34) and unscrew the Controller Assembly (35) which has a **left-hand thread**. This requires a clockwise rotation for removal.

CAUTION

Use only the special 88V60-950 Controller Wrench for removing the Controller Assembly. Do not attempt to disassemble the Controller. It is available only as a unit and is guaranteed for the life of the tool if it is not abused.

10. If the Rear Rotor Bearing (36) needs to be replaced, insert the Rear Rotor Bearing into the 99V60-A952 Bearing Clamp and tighten the nut on the fixture. Insert the 99V60-951 Seal Pressing Tool in the center of the Rear Rotor Bearing and press off the Controller. Release the clamp.
11. Lift off the Rotor Bearing Seal (36), Bearing Cage (37) and Rear End Plate (39).
12. Lift off the Cylinder (40).
13. Remove the Vanes (42).
14. Withdraw the Rotor (41) and lift out the Rotor Key (43).
15. Remove the rotor shaft and end plate assembly from the vise. Grasp the Front End Plate (44) in one hand and tap the small diameter end of the rotor shaft with a soft hammer to remove the end plate.
16. If the Front Rotor Bearing (45) is to be replaced, press it from the rotor shaft.
17. Unscrew the Oil Chamber Plug (24) from the Throttle Handle Assembly (1) and pour the oil from its reservoir.
18. Place the Throttle Handle Assembly (1) in a vise to remove the Inlet Bushing (4), Inlet Bushing Screen (5) and the Throttle Valve Spring (6). The Bushing has an interference thread and is tightly fit.
19. Drive out the Throttle Lever Pin (13) to release the Lever Assembly (14).
20. Release the Throttle Valve (2) by tapping the end of the handle with a soft hammer, or by using lock ring pliers.
21. Release the Throttle Valve Seat Support (7) by tapping the end of the handle with a soft hammer.
22. Remove the Valve Seat Screw (8), Valve Screw Lock Washer (9), Valve Seat Washer (10) and Valve Seat (11). The Air Strainer Screen (12) may now be cleaned.

Assembly

General Instructions

1. Always press on the **inner** ring of a ball-type bearing when installing the bearing on a shaft.
2. Always press on the **outer** ring of a ball-type bearing when pressing the bearing in a bearing recess.
3. Whenever grasping a tool or part in a vise, always use leather-covered or copper-covered vise jaws to protect the surface of the part and help prevent distortion. This is particularly true of threaded members and housings.
4. Always clean every part, and wipe every part with a thin film of oil before installation.

Assembly of the Throttle and Inlet

1. Assemble the Valve Seat Support Parts. Tighten the Valve Seat Screw (8) to 12 in-lb (1.4 Nm) torque.
2. Insert the Assembly in the handle, large diameter first. Locate a punch on the flat of the screw head and tap it with a hammer until the assembly is firmly seated.
3. Apply O-ring lubricant to the Seals (3). Fit the seals to the Throttle Valve (2) and push the assembly, small diameter first, into the handle until it seats firmly.
4. Assemble the Locking Lever Assembly (14) as illustrated in Dwg. TPD563 and TPD646.

For Lever Handle Models

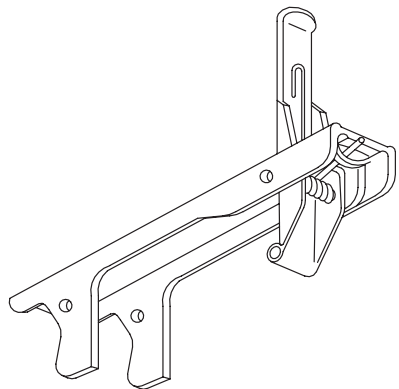

(Dwg. TPD563)

For Grip Handle Models

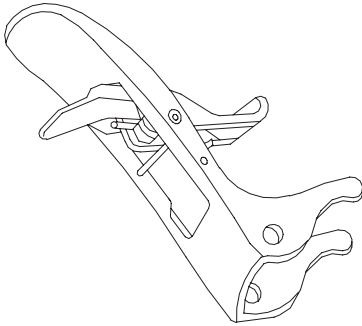

(Dwg. TPD646)

Locking Lever Assembly for 88H Grinders

- Align the holes in the Lever Assembly (14) with the slots in the Throttle Handle. With a soft hammer, tap the Throttle Lever Pin (15) through the Lever Assembly. File off any sharp edges. Operate the mechanism internally by hand to assure operation.
- Grasp the Throttle Handle in a vise.
- Insert the Throttle Valve Spring (6) small end first.
- Clean the face of the Inlet Bushing (4) and the Inlet Bushing Screen (5) with kerosene, blow dry with air before assembling into the tool. Insert the parts in the end of the Throttle Handle. With a Wrench tighten the Inlet Bushing (4) to 35 to 45 ft-lb (47-61 Nm) torque.

Assembly of the Motor

- Using an arbor press, press against the inner race of the bearing to install the Front Rotor Bearing (45) onto the Rotor Shaft (47).
- Inspect the Front End Plate (44) for nicks or burrs. Replace if necessary. Install the Front End Plate over the Rotor Shaft (47) and onto the Front Rotor Bearing (45). This is a light press fit.
- Hold the Rotor Shaft in a vise. Insert the Rotor Key (43) in the slot of the Rotor (41). The Rotor has a staked keyway on one end. Place that end up, over the rotor shaft. Apply a light film of the recommended oil to each Vane (42) and insert one vane, straight edge out, into each slot in the Rotor. If any new vanes are required, replace the entire set.
- Place the Cylinder (40) over the Rotor matching the Cylinder Dowel hole to the alignment hole in the Front End Plate (44), with the kidney port to the **right** of the dowel hole.
- Apply the Rear End Plate (39) with the kidney port to the **right** of the dowel hole.

NOTICE

If the Controller Assembly (35) needs to be replaced, you must also replace the Rotor Bearing Seal Assembly (36) which consists of the Rear Rotor Bearing and Rotor Bearing Seal. If either the Rear Rotor Bearing or Rotor Bearing Seal needs to be replaced, BOTH must be replaced with a new Bearing and Seal. Do not mix old and new parts.

- Check the outside diameter and large inside diameter of the Rotor Bearing Seal for wear. If the outside diameter of the hub is worn to 1.1764" or smaller, and/or the large inside diameter is worn to 0.9103" or larger, install a new Rotor Bearing Seal Assembly (36).

NOTICE

Take all measurements 30 degrees to the left of the dowel hole when facing the hub side of the Seal. Install the Rotor Bearing Seal.

- Press the Rear Rotor Bearing onto the hub of the Controller.

- Slip the Controller Assembly over the Rotor Shaft. Rotate the Controller counterclockwise since this is a left-hand thread.

CAUTION

Use only the special No. 88V60-950 Controller Wrench for applying the assembly.

WARNING

Tighten the Controller to 14 to 16 ft-lb (19.0 to 21.7 Nm) torque. Do not exceed 16 ft-lb. The Controller may be damaged if this torque is exceeded.

Always check the free speed of a Grinder after it has been reassembled and before it is put back into service. Refer to the Test and Inspection Procedure.

Never use a Grinder which runs in excess of the maximum speed listed in the Test and Inspection Procedure.

- Install the Controller Retaining Ring (34), **concave** face closest to the Controller.
- Grasp the Throttle Handle Assembly (1) in a vise, wide end up with the Throttle Lever facing right.
- Insert the assembled motor into the Throttle Handle Assembly (1) aligning the Cylinder Dowel (46) with the upper left-hand dowel pin hole.
- Lightly dampen the Arbor Housing Gasket (32) with oil and align it with the holes in the Throttle Handle Assembly (1).
- Insert the two Motor Clamp Washers (48) over the spline of the Rotor Shaft, concave side up so the inner rim contacts the Front End Plate (44).
- Place the Arbor Housing (29) onto the Throttle Handle Assembly (1).

NOTICE

Make sure THE NOTCH on the face of the Arbor Housing lines up with the Cylinder Dowel of the motor. Exhaust will be to the right of the operator.

NOTICE

Rotating the housing and motor and aligning the Cylinder Dowel with each of the dowel pin holes changes the direction of exhaust 90 degrees.

- Place Lock Washers on the Arbor Housing Screws (30) and slightly tighten opposite screws; then tighten all screws to 14 ft-lb (19 Nm) torque.
- Install the Exhaust Baffle (26), Exhaust Diffuser (27) in models where used and the Exhaust Deflector (25) and Exhaust Deflector Gasket (26A) in the Arbor Housing. Insert the Exhaust Deflector Screws (28) and tighten with the No. R2J-562 Deflector Screw Wrench.

Assembly of the Arbor

- For Model 88HL90L10**, insert the Dust Washer (55) followed by the Bearing Cap Spring (57), concave side first, into the Bearing Cap (56). Slide the Bearing Cap followed by the Arbor Bearing onto the Arbor shaft from the rear.
- Press the Arbor Bearing (62) onto the Arbor Shaft (58).
- Grasp the Arbor Shaft in a vise, spline end up.
- Install the Bearing Lock Washer (61) and Bearing Locknut (60). Tighten the Locknut snugly. Bend the tangs of the Bearing Lock Washer into the grooves of the Bearing Locknut.
- Remove the Arbor Shaft from the vise.
- Grasp the Arbor Housing (29) in a vise, Guard end up.
- Coat the spline of the Rotor Shaft (47) and the spline of the Arbor Shaft (58) or (59) with 3 to 4 cc of **Ingersoll Rand** No. 28 Grease. Insert the Arbor Coupling (49) into the Arbor Housing and onto the spline of the Rotor Shaft. Slip the spline of the Arbor Shaft into the Arbor Coupling.

- For **Type 1 Wheels**, place the Wheel Guard (54) onto the Arbor Housing (29), making sure the holes are aligned. Install the Guard Screw Lock Washers (53) and Guard Screws (55). Tighten to 15 ft-lb (20.3 Nm) torque.
- Install a Wheel Flange (51), Wheel and the other Wheel Flange (51) onto the Arbor (58).

NOTICE

Slip the flanges onto the arbor so the keys are opposite each other.

- Using an applicable Spanner Wrench inserted into the pin hole of the flange to hold the arbor, install the Wheel Nut (51) with an open-end wrench. Only tighten sufficiently to drive the wheel and prevent slippage.

- For **Cone Wheel (Model 88HL90L10)**, thread the Bearing Cap on the Arbor Housing and tighten to 40 to 45 ft-lb (54 to 61 Nm) torque.
- Using a No. R3F-340 Cone Wheel Arbor Wrench to hold the Arbor (59), install the cone wheel turning clockwise until hand-tight.
- Fill the oil chamber with the recommended oil and insert the Oil Chamber Plug (24). Tighten to 4 ft-lb (5.4 Nm) torque.

Test and Inspection Procedure

 **WARNING**

Disconnect the grinder from the air supply hose and shut off air to the tool before proceeding with the Test and Inspection Procedure.

Run the performance tests at 90 psig (6.2 bar/620 kPa) air pressure at the inlet of the tool with an eight foot (2.44 m) length of 3/4" (19 mm) diameter air supply hose.

- Without a wheel on the tool, operate the Grinder with the Throttle Lever fully depressed and check the free speed by applying a hand-held tachometer to the spindle end. The minimum and maximum allowable free speeds are as follows:

Model	Stamped	Free Speed	
		Minimum	Maximum
88H60	6000	5650	6050
88H90	9000	7950	8550

- Test the Grinder motor for power to determine these **minimum** performance levels. The Throttle Lever must not be actuated repeatedly during the test. Depress the Lever and hold it in the open position until the test is complete.

Model	Torque		Speed, rpm (r/min)
	ft-lb	Nm	
88H60	1.89	2.6	5000
88H90	1.60	2.2	6500

If a dynamometer is not available, test the Grinder using a properly calibrated test fan and fan cage combination to determine the following **minimum** speeds:

Model	Fan	Minimum Speed, rpm (r/min)
88H60	R3	4700
88H90	R2	5700

- There must be no objectionable leaks in any non-exhaust area. The Throttle must not leak when it is closed.
- There must be no leaks past the closed Throttle that will run the motor.
- The Grinder must start smoothly when the Throttle Lever is depressed and must shut off completely when the Throttle Lever is released.
- The Grinder must be equipped with a spring-loaded window style Lock (17). The Lock must return to the locked position when the Throttle Lever is released.
- The tool must run smoothly without noticeable vibration or unusual sound.
- The Arbor (58 or 59) must turn freely with no evidence of brinelled bearings.
- The Threads on the arbor must be free of nicks and damage.
- The Nameplate must be legible, in place and securely fastened. Make replacement if necessary.

Troubleshooting Guide

Trouble	Probable Cause	Solution
Low power or low free speed	Low air pressure at the Inlet	Check the air pressure at the Inlet. For maximum performance and durability of parts, the pressure must not exceed 90 psig (6.2 bar/620 kPa).
	Plugged Screens	Clean the Screens in a clean, suitable cleaning solution in a well ventilated area. If the screen cannot be cleaned, replace it. <div style="text-align: center;"> WARNING</div> <p>Never operate a Grinder without an inlet screen. Ingestion of dirt into the Grinder can, in some cases, cause an unsafe condition.</p>
	Worn or broken Vanes	Replace a complete set of Vanes.
	Worn or broken Cylinder	Replace the Cylinder if it appears cracked or if the bore is wavy or scored.
	Improper lubrication or dirt build-up in the motor	Lubricate the Grinder as instructed in LUBRICATION. If lubrication does not result in satisfactory operation, disassemble the motor, inspect and clean all parts.
High free speed	Worn Rotor Bearing Seal	Replace the Rotor Bearing Seal Assembly if the outside diameter of the hub is worn to 1.1764" or smaller and/or the large inside diameter is worn to 0.9103" or larger.
Rough operation	Worn or broken Rear Rotor Bearing or Front Rotor Bearing	Examine each Bearing. Replace Rotor Bearing Seal Assembly or Front Rotor Bearing if worn or damaged.
	Worn Rotor Key	Replace the Key. Check the Rotor Shaft or Rotor for key slot wear and replace if necessary.
	Bent Arbor	Mount the Arbor on centers. Check the bearing diameter for runout with an indicator. Replace the Arbor if runout exceeds 0.002" (0.051 mm) Total Indicator Reading.
Scoring	Improper assembly	Make certain that all motor parts are properly aligned prior to clamping the motor assembly.
Air leaks	Worn Valve Seat or Valve Seat Washer	Replace worn parts.
	Worn Throttle Valve Seals	Replace both Seals.
	Worn Arbor Housing Gasket	Replace the Gasket.
	Oiler Plug worn or not tight	Tighten the Plug. If the problem persists, replace the Plug.

Related Documentation

For additional information refer to:

Product Safety Manual Information Manual 04584959.

Product Information Manual 16573214 and 16576100.

Parts Information Manual 16573289.

Manuals can be downloaded from ingersollrandproducts.com.

ingersollrandproducts.com

© 2014 *Ingersoll Rand*

